



FORCE & TORQUE MEASUREMENT
ISO 9001 & ISO/IEC 17025 ACCREDITED

IMADA, Inc.®

3100 Dundee Rd., Suite 707, Northbrook, IL 60062
Tel: 847-562-0834 Fax: 847-562-0839
www.imada.com E-mail: imada@imada.com

KST2 Spring Tester

- Hand wheel design provides a high degree of precise control
- One stand for both compression (push) and tension (pull) tests
- Gauge remains in place when hand wheel is released
- Stroke: 9" stroke
- Max clearance 9" (with extender 14")
- Capacity 110 lbf

Distance Meter Specifications	
Display	Push button for inch/mm, zero set and on/off
Resolution	0.0005"/0.01mm
Accuracy	0.1% of reading or 0.005"/0.1mm, whichever is greater



The KST2 Series offers the precise control of a hand wheel test stand and measures both compression and tension without any conversion. It is equipped with a precision digital distance meter. IMADA force gauges are available in capacities of a few ounces up to 110 lbf. Consult our engineers for custom applications.

KST2 Ranges (Resolution) Accuracy: ±0.2% F.S. ±1 LSD

Model	Capacity (Resolution)		
	Pounds (Ounces)	Kilograms (Grams)	Newtons
KST2-0.5	7.00 (0.01 ozf)	200.0 (0.1 gf)	2.000 (0.001 N)
KST2-1	18.00 (0.01 ozf)	500.0 (0.1 gf)	5.000 (0.001 N)
KST2-4	4.400 (0.001 lbf)	2.000 (0.001 kgf)	20.00 (0.01 N)
KST2-11	11.00 (0.01 lbf)	5.000 (0.001 kgf)	50.00 (0.01 N)
KST2-44	44.00 (0.01 lbf)	20.00 (0.01 kgf)	200.0 (0.1 N)
KST2-110	110.0 (0.1 lbf)	50.00 (0.01 kgf)	500.0 (0.1 N)

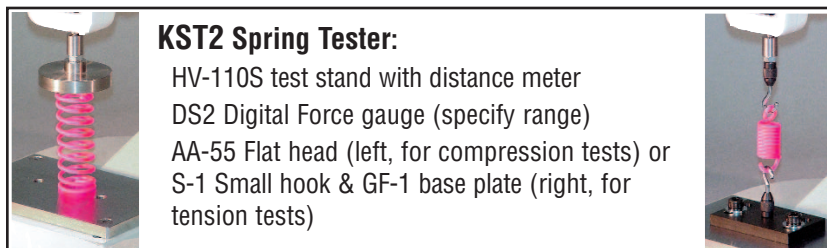

KST2 Spring Tester:

HV-110S test stand with distance meter
DS2 Digital Force gauge (specify range)
AA-55 Flat head (left, for compression tests) or
S-1 Small hook & GF-1 base plate (right, for tension tests)

Note: Other special attachments are available for different applications.

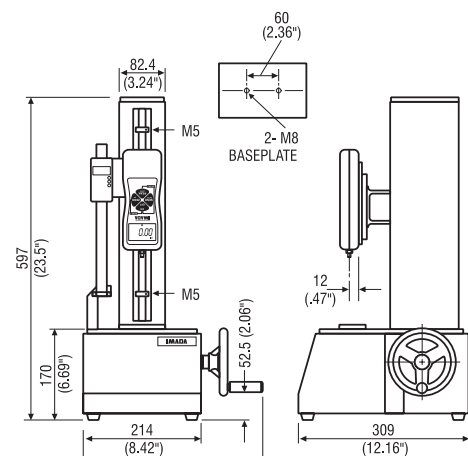

Use DB-2 data button to collect both force and displacement data for analysis with SW-2 Imada data acquisition software.

