

Motorized Vertical Test Stand

MX-110S with Distance Meter
MX-110-TM with Timer

MX-110 without Distance Meter
MX-110S-TM with Timer & Distance Meter

- One stand for both compression (push) and tension (pull) tests
- Max clearance 9" (with extender 14")
- Maximum load 110 lbf
- Jog, Single Cycle, Continuous Cycle (72 hour max.), Force Control
- Combination of screw drive system and high performance brushless motor provides extremely smooth and powerful operation over the entire speed range.
- Wide speed range: 0.4 – 11.8 in/min (optional speed ranges available)
- Force Controlled operation with Imada Z2 force gauges
- Optional digital distance meter and speed indicator available
- Conditional Overload Prevention

Speed Configurations	
Standard Speed	0.4~11.8"/min
Optional Speeds	
MX-110-F	0.8~23.6"/min
MX-110-WF	1.5~47.2"/min
MX-110-O	0.1~ 2.3"/min

Custom Configurations Available
Specify speed when ordering.

Timer Specifications	
Range	1 sec ~ 99 min, 59 sec
Accuracy	±0.01%, ±0.05 sec; in 1 second intervals



MX-110 with Timer
Force gauges and attachments are sold separately.



MX-110 test stands offer consistent testing and force control capability. The combination of screw drive system and state-of-the-art brushless motor provides extremely smooth and powerful operation over the entire speed range.

Connect the MX-110 test stand with an Imada Z Series force gauge to enable force controlled testing and Conditional Overload Prevention.

High/Low Set Point Force Control

Force control is activated when the applied force is at or between the high and low set point(s) of the Z Series force gauge and is deactivated by the digital timer. Initial carriage speed is controlled by the variable or fixed speed settings.

One Way Force Control

Initial carriage speed is controlled by the variable or fixed speed settings. When the applied force reaches the low set point of the Z Series force gauge, the test stand's carriage speed is adjusted to 20% of maximum and decreases to zero as the applied force reaches the high set point. Ideal for creep or non-destructive testing.

The MX-110 accepts any of the standard range Imada force gauges. Quick switch and Emergency Stop features are also included.

AP-002 Adapter Plate is available to mount most other force gauges to IMADA test stands.

Digital Distance Meter

- Mounts to all test stands, manual or motorized
- Data output capability



Distance Meter Specifications	
Display	Push button for inch/mm, zero set and on/off
Resolution	0.0005"/0.01mm
Accuracy	0.1% of reading or 0.005"/0.1mm, whichever is greater

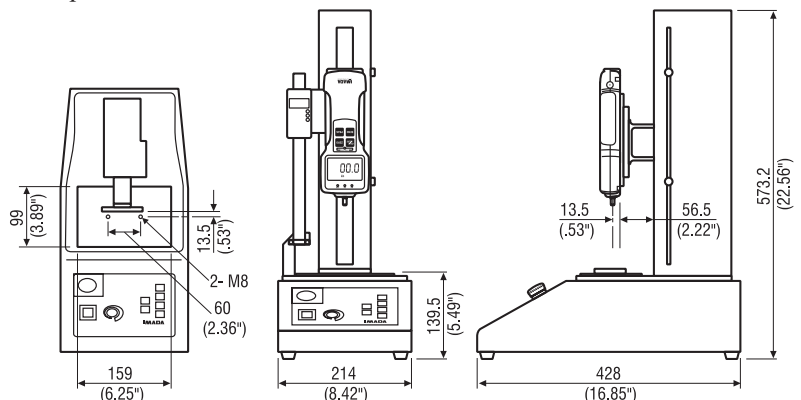

Specifications subject to change without notice.